

ARFF 9-8-21 Contact Discrimination exercises

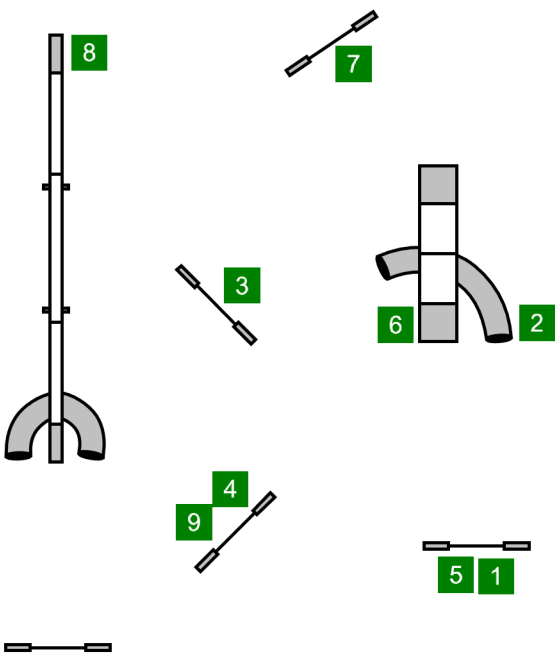

Try with and without a lead out.

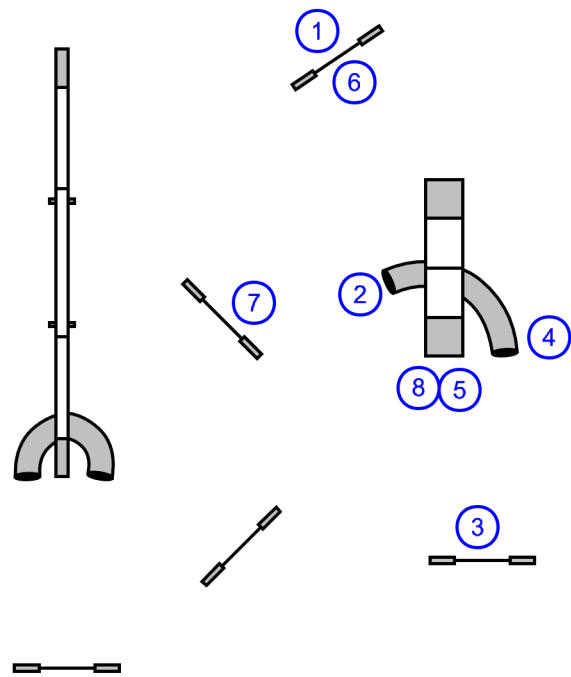

Where do you want to be when your dog exits #2?  
When he exits #4 to ensure he gets a good entry to the A-frame and will continue on to #6?

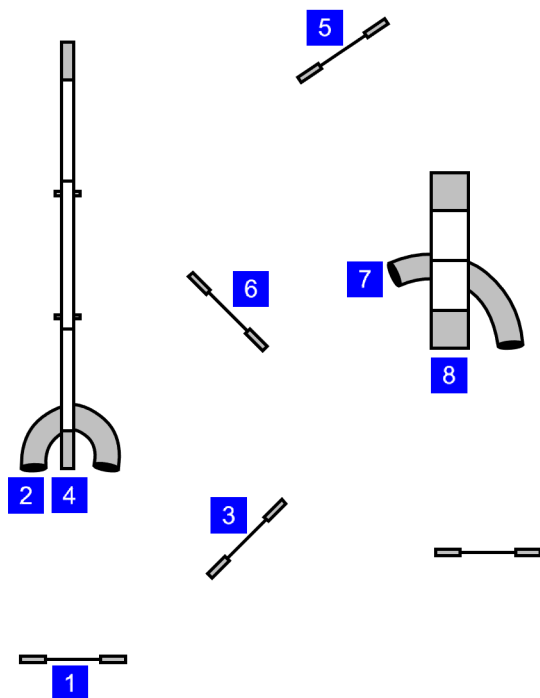

How will you signal your dog for #2 and #4?  
Which way to turn your dog after #6?

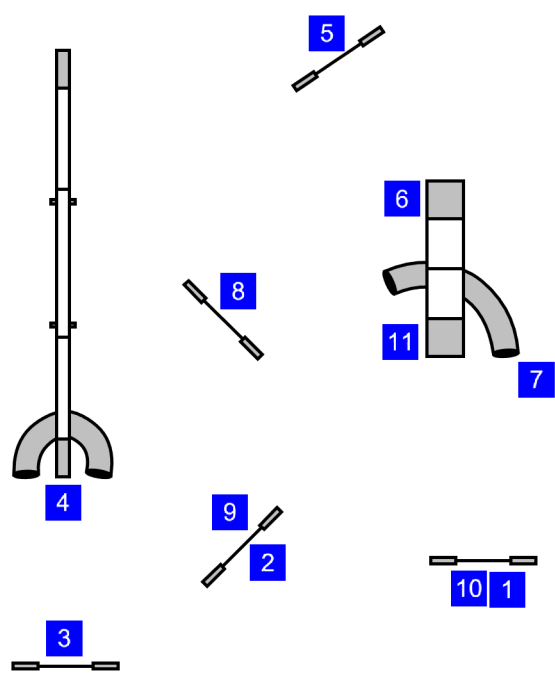

Get as close to #2 to start as you can. You should be able to pull your dog to the #11 A-frame if he's on your right.